

规格书编号

**SPEC NO: HDFB05RSSB5SP05**

# 产品规格书

# SPECIFICATION

CUSTOMER 客户: \_\_\_\_\_

PRODUCT 产品: \_\_\_\_\_ SAW FILTER \_\_\_\_\_

MODEL NO 型号: \_\_\_\_\_ HDFB05RSS-B5 \_\_\_\_\_

MARKING 印字: \_\_\_\_\_ B115 \_\_\_\_\_

PREPARED 编制: \_\_\_\_\_ CHECKED 审核: \_\_\_\_\_

APPROVED 批准: \_\_\_\_\_ D A T E 日期: \_\_\_\_\_ 2016-12-1 \_\_\_\_\_

客户确认 CUSTOMER RECEIVED:		
审核 CHECKED	批准 APPROVED	日期 DATE

无锡市好达电子有限公司  
Shoulder Electronics Limited

Factory Address: NO. 115, Gaoyun Road, Binhu Economic & Technology Development Area, Wuxi, Jiangsu, China. Tel: 86-510-85629111  
Country of origin: China

## 更改历史记录 History Record

更改日期 Date	规格书编号 Spec. No.	产品型号 Part No.	客户产品型号 Customer No.	更改内容描述 Modify Content	备注 Remark
2015-11-27	SP00	HDFB05RSS -B5		NEW SPEC.	
2016-05-06	SP01	HDFB05RSS -B5		Complete specifications. Add product application, reliability and other information.	
2016-08-23	SP02	HDFB05RSS -B5		Change carrier tape size.  Carrier tape encryption.	10. TAPE SPECIFICATIONS  [Figure 1] Carrier Tape Dimensions
2016-11-17	SP03	HDFB05RSS -B5		Optimize insertion loss.	5. ELECTRICAL SPECIFICATION
2016-11-25	SP04	HDFB05RSS -B5		Correction device size. Thickness changed from 0.5max. to 0.65max	2. Package Dimension
2016-12-01	SP05	HDFB05RSS -B5		Optimized rejection segmentation.	5. ELECTRICAL SPECIFICATION

### 1. Application

- Low-loss RF filter for mobile telephone Cellular / WCDMA Band V systems.
- Impedance 50 ohm input and output.
- Unbalanced to unbalanced operation.
- Useable passband 25 MHz.
- RoHS compatible.

### 2. DIMENSION (PKG SIZE 1.1 x 0.9mm)

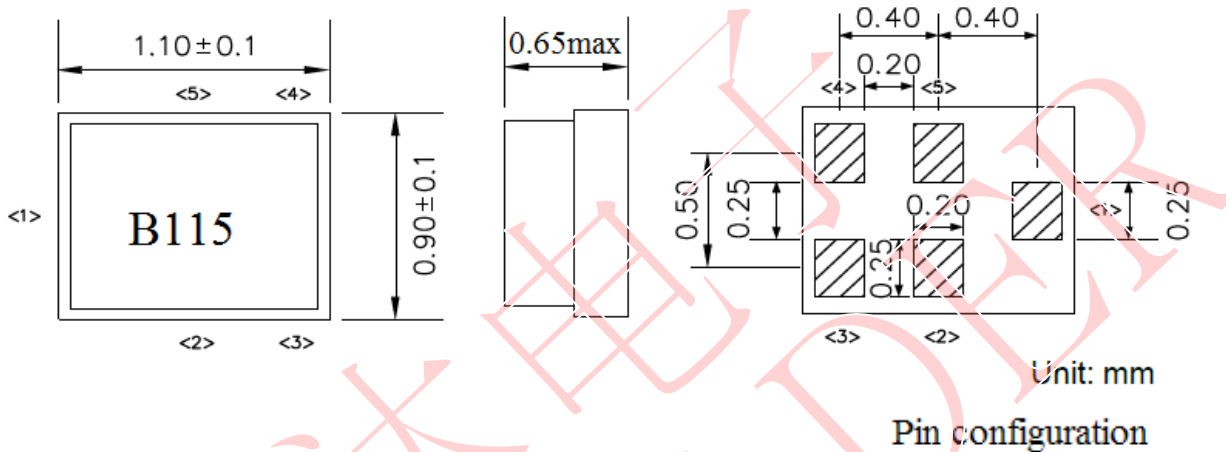

- 1. Input
- 4. Output
- 2,3,5 To be grounded

### 3. Maximum Rating

Items	Conditions
Operation temperature rang	-30°C ~ +85°C
Storage temperature rang	-40°C ~ +85°C
ESD voltage	ESD(MM) : 50VDC
Sensitive discharge device	ESD(HBM) : 175VDC
DC Voltage VDC	5V
Max Input Power	15dBm 2000h
Moisture Sensitivity Level	MSL 2

### 4. Test Circuit

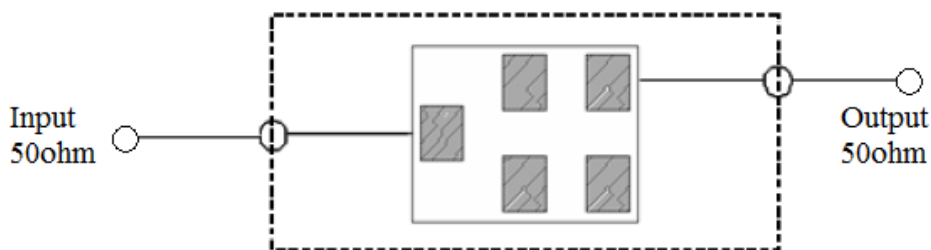

< X-ray Top View >

## 5. ELECTRICAL SPECIFICATION

**Table1. Electrical Specification**

Temperature range for specification: T = -20~+80°C  
 Terminating source impedance: Zs = 50Ω unbalanced  
 Terminating load impedance: Zl = 50Ω unbalanced  
 Input power: 15dBm 2000h

Item	Condition (MHz)	Specification			Unit
		Min	Typ	Max	
Insertion loss	869~894	-	1.7	1.9	dB
Pass band ripple	869~894	-	0.4	1.0	dB
VSWR	869~894	-	1.5	1.8	-
Absolute attenuation	45	50	60	-	dB
	779~804	46	55	-	dB
	824~849	42	47	-	dB
	846.5~854	35	45	-	dB
	1693~1743	38	45	-	dB
	1738~1788	38	45	-	dB
	2400~2500	35	40	-	dB
	2607~2682	33	40	-	dB
	3476~3576	30	35	-	dB
	4345~4470	30	35	-	dB
	5214~5364	30	35	-	dB
	5725~5875	30	35	-	dB
	6083~6258	30	35	-	dB
6952~7152	30	35	-	dB	
7821~8046	30	35	-	dB	

## 6. Typical frequency response

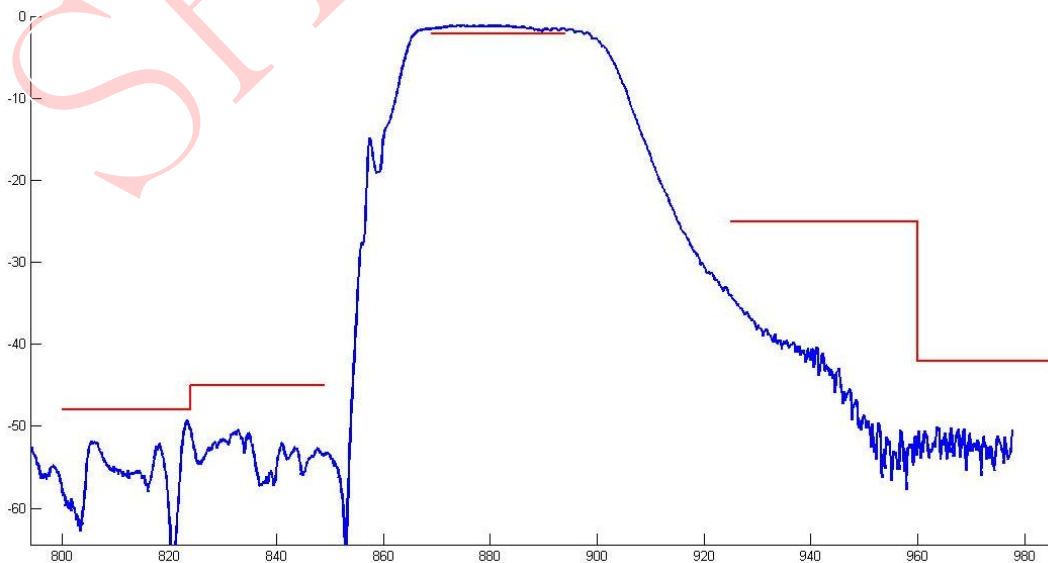

**7. ENVIRONMENTAL CHARACTERISTICS**

7.1 High temperature exposure

Subject the device to +85°C for 16 hours. Then release the filter into the room conditions for 24 hours prior to the measurement. It shall fulfill the specifications in 5.

7.2 Low temperature exposure

Subject the device to -40°C for 16 hours. Then release the device into the room conditions for 24 hours prior to the measurement. It shall fulfill the specifications in 5.

7.3 Temperature cycling

Subject the device to a low temperature of -40°C for 30 minutes. Following by a high temperature of +85°C for 30 Minutes. Then release the device into the room conditions for 24 hours prior to the measurement. It shall meet the specifications in 5.

7.4 Resistance to solder heat

- 1、immerge the solder bath at 260°C for 10 sec.
- 2、the iron at 370°C for 3 sec

7.5 Solderability

Submerge the device terminals into the solder bath at 245°C ± 5°C for 5s, More than 95% area of the soldering pad must be covered with new solder. It shall meet the specifications in 5.

7.6 Reflow soldering

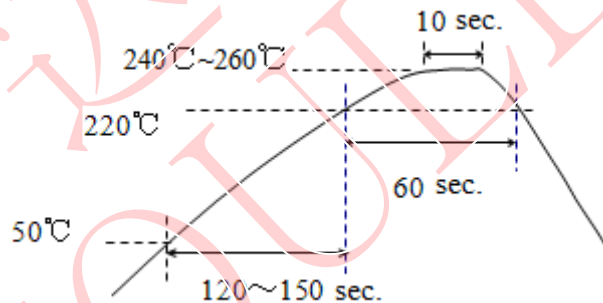

The specimen shall be passed through the reflow furnace with the condition shown in the above profile for 1 time.

The specimen shall be stored at standard atmospheric conditions for 1h, after which the measurement shall be made. Test board shall be 1.6 mm thick. Base material shall be glass fabric base epoxy resin.

7.7 Mechanical shock

Drop the device randomly onto the concrete floor from the height of 1m 3 times. the device shall fulfill the specifications in 5.

7.8 Vibration

Subject the device to the vibration for 1 hour each in x,y and z axes with the amplitude of 1.5 mm at 10 to 55 Hz. The device shall fulfill the specifications in 5.

**8. REMARK**

8.1 Static voltage

Static voltage between signal load & ground may cause deterioration & destruction of

the component. Please avoid static voltage.

8.2 Ultrasonic cleaning

Ultrasonic vibration may cause deterioration & destruction of the component. Please avoid ultrasonic cleaning

8.3 Soldering

Only pad component may be solded. Please avoid soldering another part of component.

**9. Packing**

9.1 Dimensions

(1) Carrier Tape: Figure 1

(2) Reel: Figure 2

(3) The product shall be packed properly not to be damaged during transportation and storage.

9.2 Reeling Quantity

10000 pcs/reel  $\phi$  178mm

9.3 Taping Structure

(1) The tape shall be wound around the reel in the direction shown below.

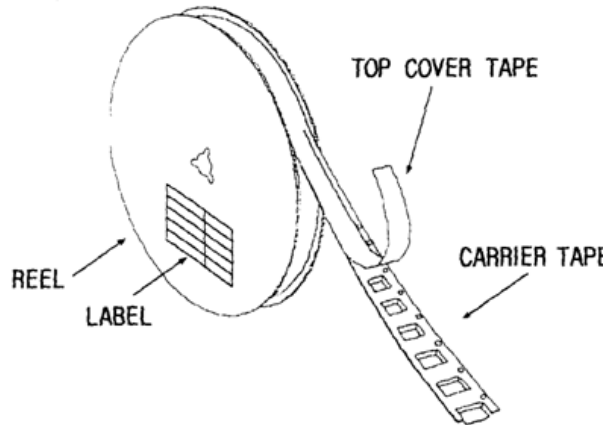

(2) Label

Device Name	
Marking	
User Product Name	
Quantity	
Lot No.	

(3) Leader part and vacant position specifications.

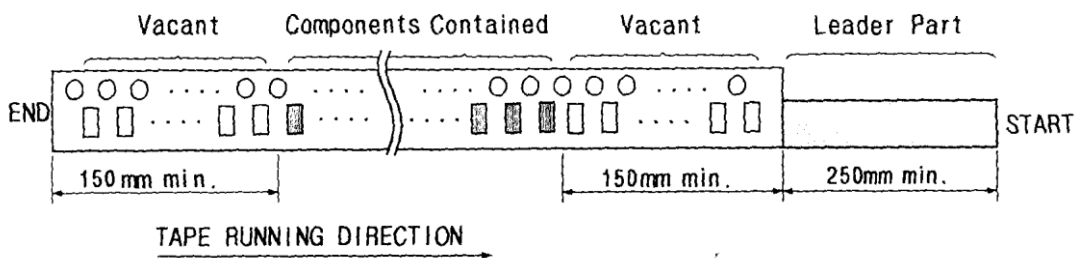

**10. TAPE SPECIFICATIONS**

10.1 Tensile Strength of Carrier Tape: 4.4N/mm width

10.2 Top Cover Tape Adhesion (See the below figure)

- (1) pull off angle: 0~15°
- (2) speed: 300mm/min.
- (3) force: 20~70g

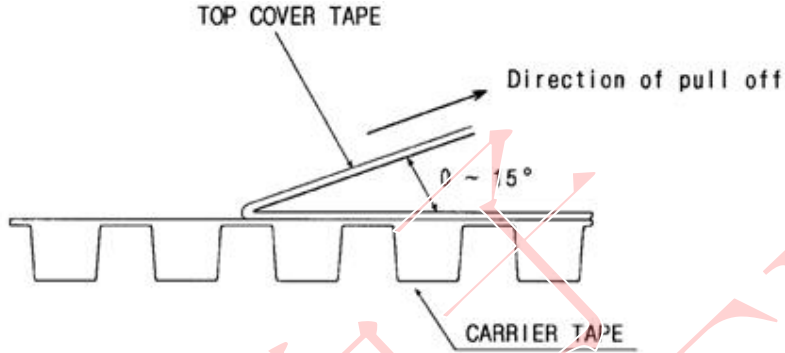

**[Figure 1] Carrier Tape Dimensions**

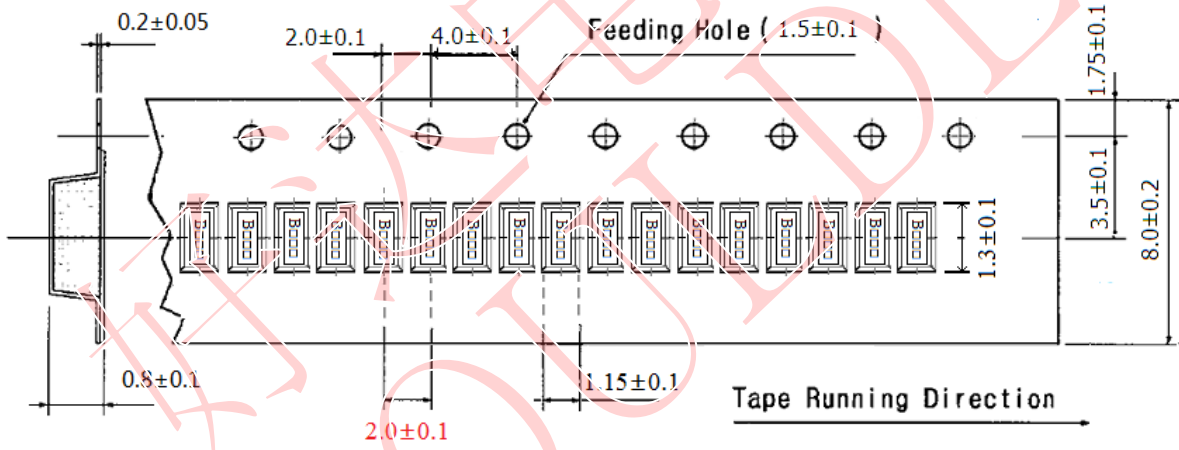

Prior to the size of 4.0±0.1, after encryption, modified to 2.0±0.1.

**[Figure 2] 10000 pcs/reel ⌀ 178mm**

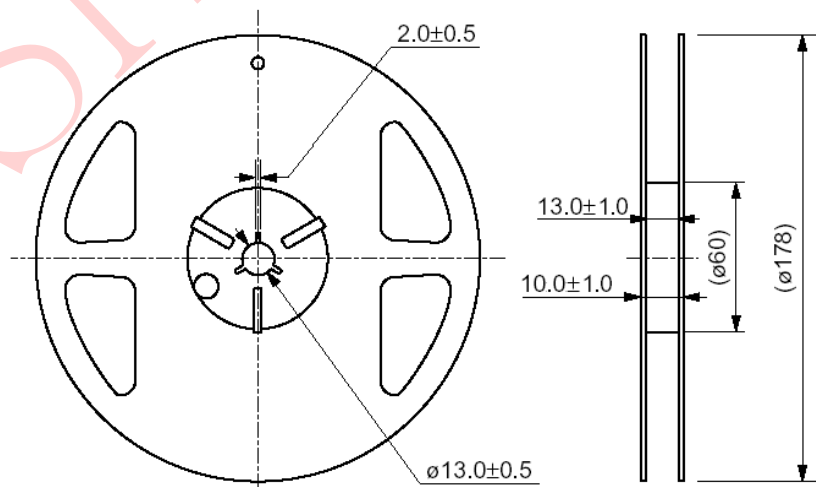

**ø178 Reel Dimension**

(in mm)