

规格书编号

SPEC NO: HDF2442TB2SP01

产品规格书

SPECIFICATION

CUSTOMER 客户: _____

PRODUCT 产品: _____ SAW FILTER _____

MODEL NO 型号: _____ HDF2442T-B2 _____

MARKING 印字: _____ B191 _____

PREPARED 编制: _____ CHECKED 审核: _____

APPROVED 批准: _____ D A T E 日期: _____ 2017-02-06 _____

客户确认 CUSTOMER RECEIVED:		
审核 CHECKED	批准 APPROVED	日期 DATE

无锡市好达电子有限公司
Shoulder Electronics Limited

Factory Address: NO. 115, Gaoyun Road, Binhu Economic & Technology Development Area, Wuxi, Jiangsu, China. Tel: 86-510-85629111
Country of origin: China

更改历史记录 History Record

更改日期 Date	规格书编号 Spec. No.	产品型号 Part No.	客户产品型号 Customer No.	更改内容描述 Modify Content	备注 Remark
2017-2-6	SP01	HDF2442T-B2		New specification.	

1. Application

- Low-loss RF filter for Bluetooth/WLAN.
- Impedance 50 ohm input and output.
- Unbalanced to unbalanced operation.
- Useable passband 82MHz.
- RoHS compatible.

2. DIMENSION

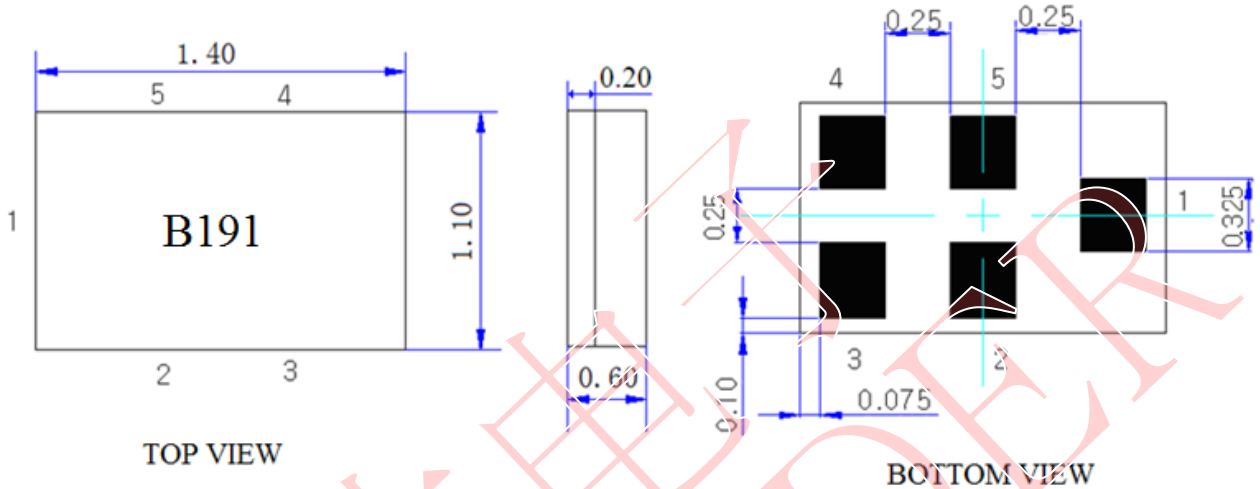

Pin configuration

- 1. Input (recommended) or Output
- 4. Output (recommended) or Input
- 2,3,5 To be grounded

3. Maximum Rating

Items	Conditions
Operation temperature rang	-30℃ ~ +85℃
Storage temperature rang	-40℃ ~ +85℃
ESD voltage	ESD(MM) : 50VDC
Sensitive discharge device	ESD(HBM) : 175VDC
DC Voltage VDC	5V (25+/-2 deg.C)
Max Input Power	24dBm 2000h

4. TEST CIRCUIT

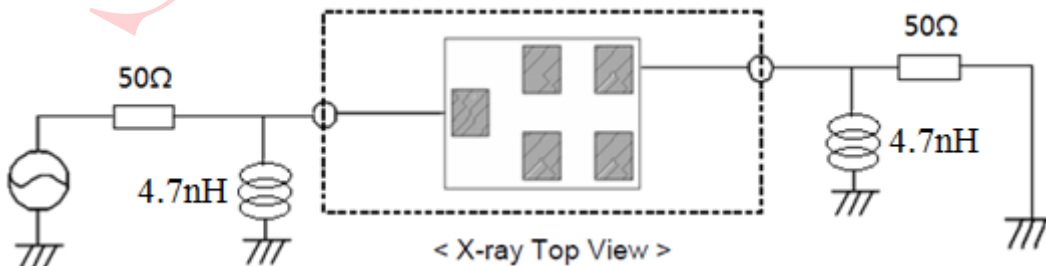

4. ELECTRICAL SPECIFICATION

Items	Test Condition	Min	Typ	Max	Unit
Center Frequency	Fc	-	2442	-	MHz
Insertion loss	2401~2483 MHz	-	1.6	1.9	dB
Amplitude Ripple (p-p)	2401~2483 MHz	-	0.6	1.2	dB
VSWR	2401~2483 MHz	-	1.6	2.0	-
Absolute Attenuation	10~1574 MHz	22	28	-	dB
	1574~1577 MHz	25	28	-	dB
	1577~1680 MHz	25	28	-	dB
	1845~1880 MHz	25	30	-	dB
	2110~2170 MHz	28	32	-	dB
	2300~2350 MHz	40	50	-	dB
	2555~2655 MHz	30	34	-	dB
	2690~4000 MHz	28	32	-	dB
	4000~5000 MHz	25	32	-	dB
5000~8000 MHz	20	28	-	dB	
Input/Output Impedance			50Ω/4.7nH		

6. Typical frequency response

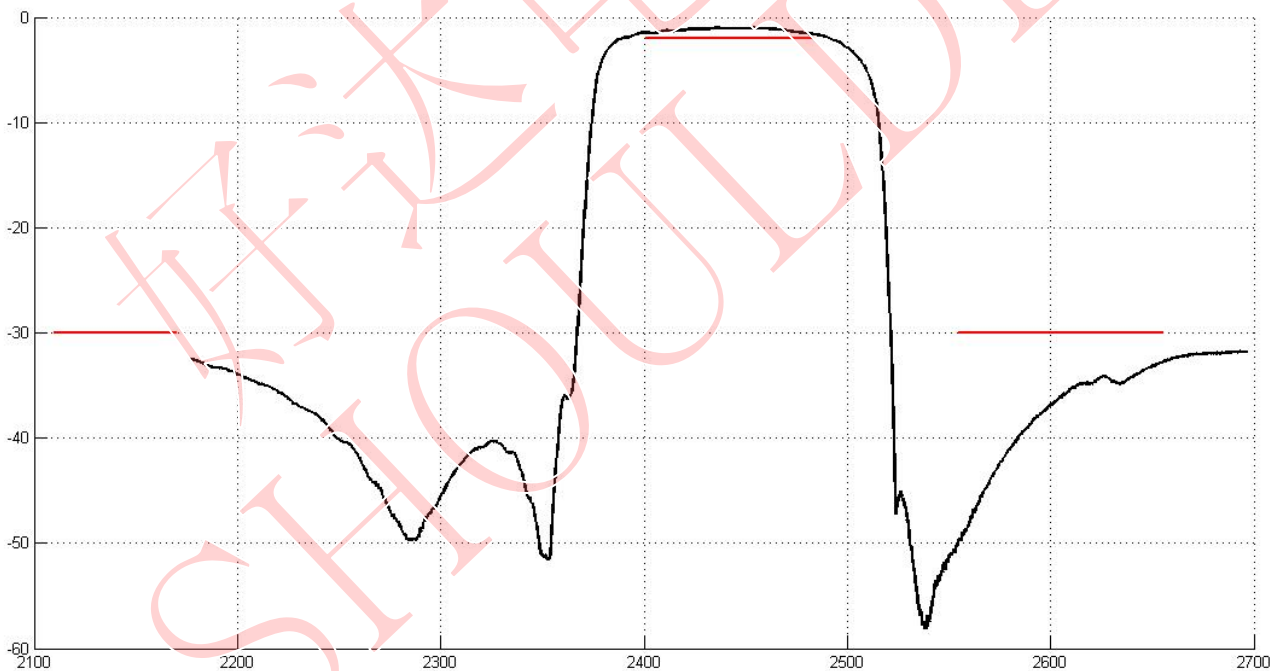

7. ENVIRONMENTAL CHARACTERISTICS

7.1 High temperature exposure

Subject the device to +85°C for 16 hours. Then release the filter into the room conditions for 24 hours prior to the measurement. It shall fulfill the specifications in 5.

7.2 Low temperature exposure

Subject the device to -40°C for 16 hours. Then release the device into the room conditions for 24 hours prior to the measurement. It shall fulfill the specifications in 5.

7.3 Temperature cycling

Subject the device to a low temperature of -40°C for 30 minutes. Following by a high temperature of +85°C for 30 Minutes. Then release the device into the room conditions for 24 hours prior to the measurement. It shall meet the specifications in 5.

7.4 Resistance to solder heat

- 1、immerge the solder bath at 260°C for 10 sec.
- 2、the iron at 370°C for 3 sec

7.5 Solderability

Submerge the device terminals into the solder bath at 245°C ±5°C for 5s, More than 95% area of the soldering pad must be covered with new solder. It shall meet the specifications in 5.

7.6 Reflow soldering

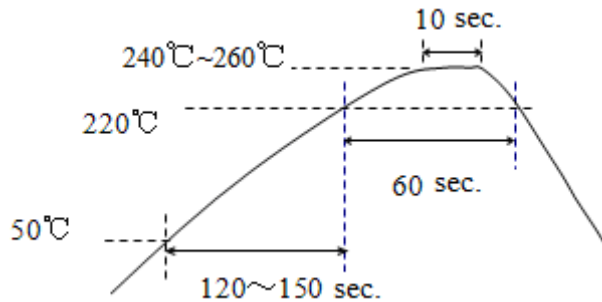

The specimen shall be passed through the reflow furnace with the condition shown in the above profile for 1 time.

The specimen shall be stored at standard atmospheric conditions for 1h, after which the measurement shall be made. Test board shall be 1.6 mm thick. Base material shall be glass fabric base epoxy resin.

7.7 Mechanical shock

Drop the device randomly onto the concrete floor from the height of 1m 3 times. the device shall fulfill the specifications in 5.

7.8 Vibration

Subject the device to the vibration for 1 hour each in x,y and z axes with the amplitude of 1.5 mm at 10 to 55 Hz. The device shall fulfill the specifications in 5.

8. REMARK

8.1 Static voltage

Static voltage between signal load & ground may cause deterioration & destruction of the component. Please avoid static voltage.

8.2 Ultrasonic cleaning

Ultrasonic vibration may cause deterioration & destruction of the component. Please avoid ultrasonic cleaning

8.3 Soldering

Only pad component may be solded. Please avoid soldering another part of component.

9. Packing

9.1 Dimensions

- (1) Carrier Tape: Figure 1
- (2) Reel: Figure 2
- (3) The product shall be packed properly not to be damaged during transportation and storage.

9.2 Reeling Quantity

10000 pcs/reel ϕ 257.5mm

9.3 Taping Structure

- (1) The tape shall be wound around the reel in the direction shown below.

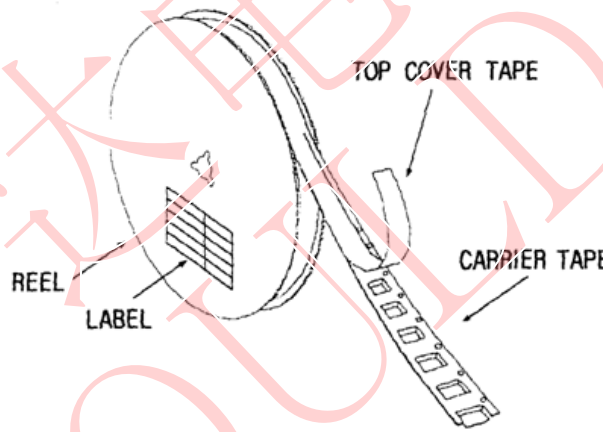

(2) Label

Device Name	
Marking	
User Product Name	
Quantity	
Lot No.	

(3) Leader part and vacant position specifications.

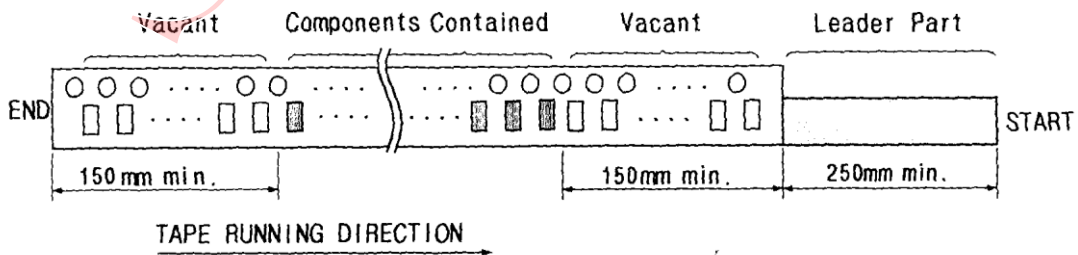

10. TAPE SPECIFICATIONS

10.1 Tensile Strength of Carrier Tape: 4.4N/mm width

10.2 Top Cover Tape Adhesion (See the below figure)

- (1) pull off angle: 0~15°
- (2) speed: 300mm/min.
- (3) force: 20~70g

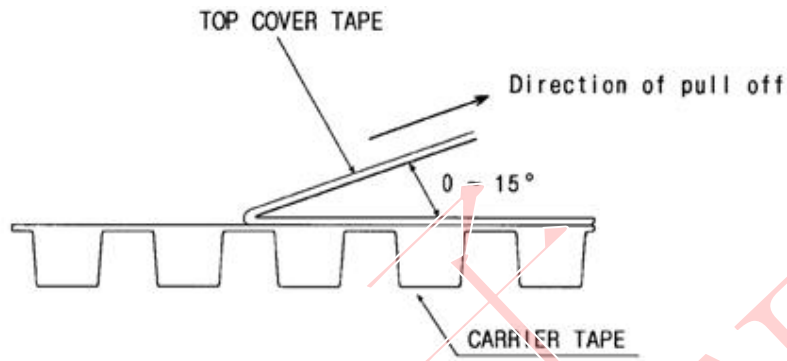

[Figure 1] Carrier Tape Dimensions

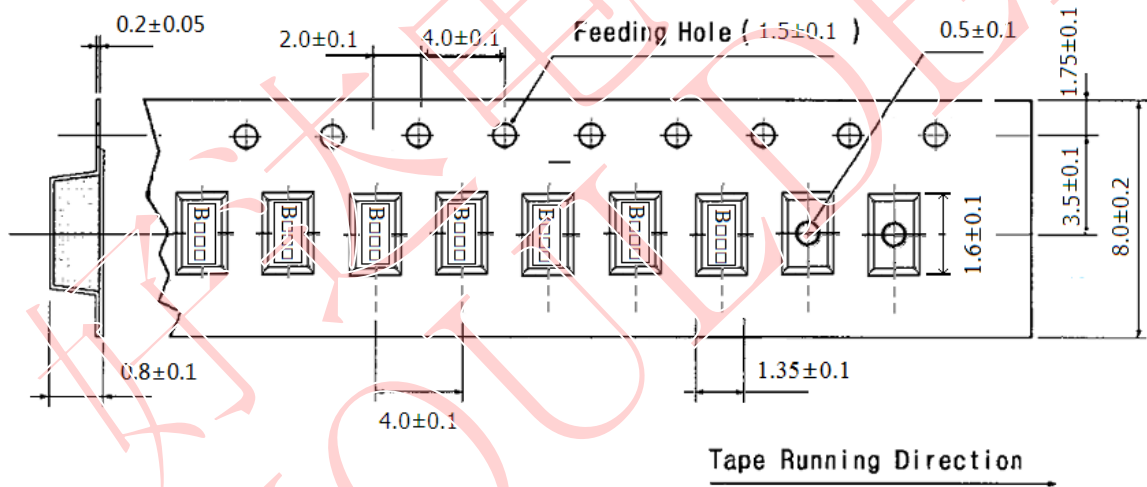

[Figure 2] 10000 pcs/reel φ 257.5mm

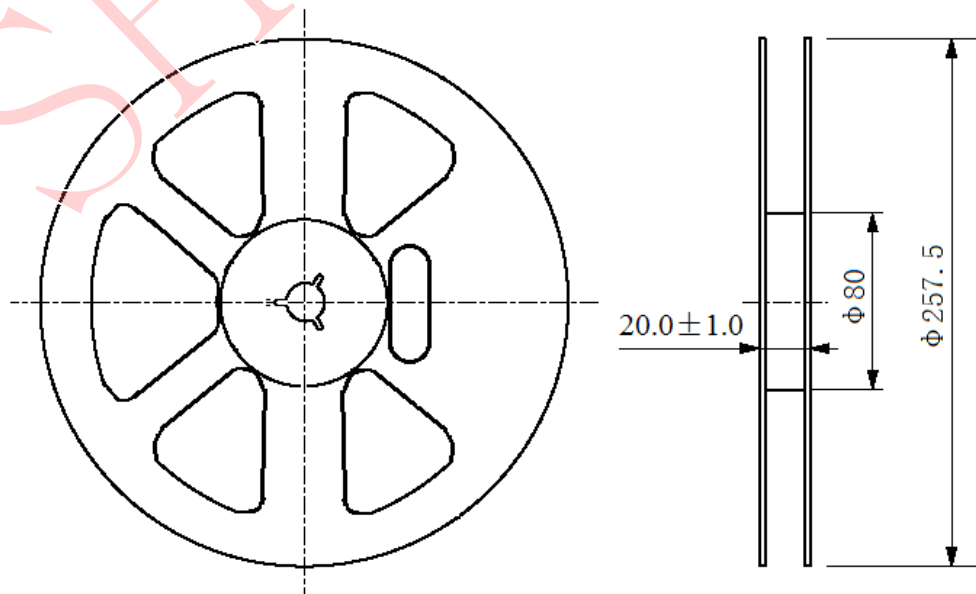

φ 257.5 Reel Dimension

(in mm)