

规格书编号

SPEC NO : HDDB08NSBB11SP01

产品规格书

SPECIFICATION

CUSTOMER 客户: _____

PRODUCT 产品: _____ SAW DUPLEXER _____

MODEL NO 型号: _____ HDDB08NSB-B11 _____

MARKING 印字: _____ B057 _____

PREPARED 编制: _____ CHECKED 审核: _____

APPROVED 批准: _____ DATE 日期: _____ 2016-5-3 _____

客户确认 CUSTOMER RECEIVED:		
审核 CHECKED	批准 APPROVED	日期 DATE

无锡市好达电子有限公司
Shoulder Electronics Limited

Factory Address: NO. 115, Gaoyun Road, Binhu Economic & Technology Development Area, Wuxi, Jiangsu, China. Tel: 86-510-85629111
Country of origin: China

更改历史记录
History Record

更改日期 Date	规格书编号 Spec. No.	产品型号 Part No.	客户产品型号 Customer No.	更改内容描述 Modify Content	备注 Remark
2015-7-29	SP00	HDDB08NSB -B11		The new specification	
2016-05-03	SP01	HDDB05NSB -B11		Complete specifications. Add product application, reliability and other information. Add downlink power.	

1. Application

- Low-loss Saw duplexer for mobile telephone LTE and WCDMA Band 8 systems
- Low insertion attenuation and low passband ripple.
- Usable passband 35MHz
- High isolation between Tx and Rx.
- Single ended to balanced transformation in Antenna - Rx path
- RoHS compatible

2. DIMENSION (PKG SIZE 1.8 x 1.4 x 0.6mm)

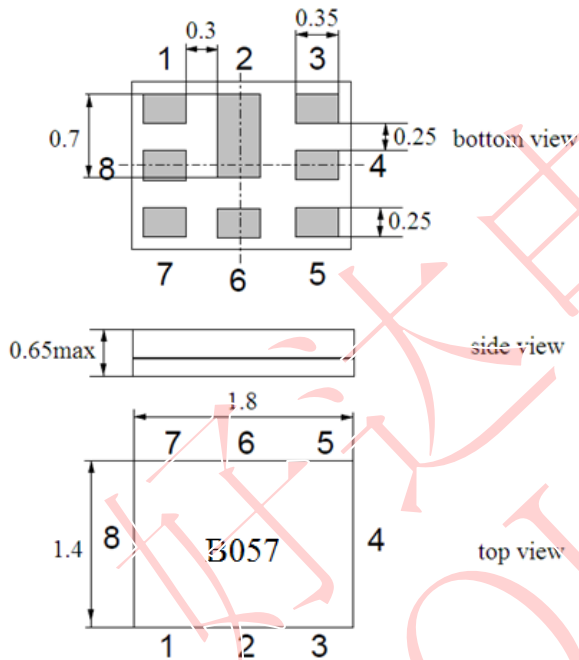

Marking: B057

Pin configuration

- 3. Tx
- 1,8 Rx balanced
- 6. Antenna
- 2,4,5,7 To be grounded

3. Maximum Rating

Items	Conditions
Operation temperature rang	-30°C ~ +85°C
Storage temperature rang	-40°C ~ +85°C
ESD voltage	ESD(MM) : 50VDC
Sensitive discharge device	ESD(HBM) : 175VDC
DC Voltage VDC	3V (25+/-2 deg.C)
Moisture Sensivity Level	MSL 2

4. TEST CIRCUIT

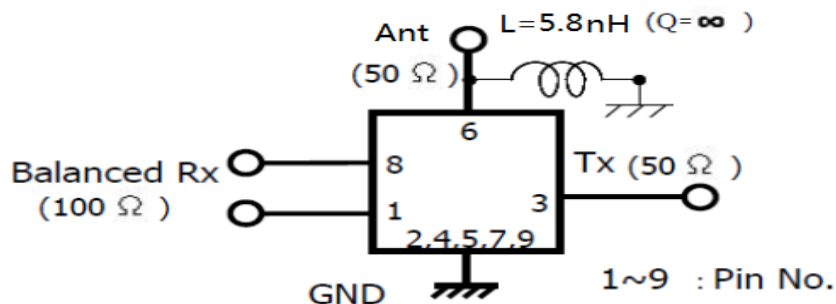

5. ELECTRICAL SPECIFICATION

Table1. Electrical Specification

Item		Condition (MHz)	Specification			Unit	
			Min	Typ	Max		
TX to ANT	Insertion loss	882.4~912.6		2.1	2.8	dB	
	Amplitude ripple	882.4~912.6		1.2	2.0		
	VSWR	ANT	882.4~912.6	-	1.5	2.0	-
				Tx	-	1.5	2.0
	Input Power		882.4~912.6	+29dBm Ta=+50°C 5000h,CW			-
	Absolute attenuation		716~728	35	45	-	dB
			728~821	35	45	-	dB
			832~862	35	42	-	dB
			927.4~957.6	40	48	-	dB
			1565~1606	37	45	-	dB
		1670~1880	27	33	-	dB	
		2110~2500	27	32	-	dB	
	2620~3520	20	27	-	dB		
ANT to RX	Insertion loss	927.4~957.6	-	2.2	2.8	dB	
	Pass band ripple	927.4~957.6		1.0	2.2	dB	
	VSWR	ANT	927.4~957.6	-	1.8	2.1	-
		Rx		-	1.8	2.1	-
	Absolute attenuation		10~880	45	60	-	dB
			882.4~912.6	45	58	-	dB
			1045~1810	35	55	-	dB
			1850~1920	40	55	-	dB
		2400~2484	40	55	-	dB	
	2775~2880	40	55	-	dB		

Table2. Electrical Specification

Item		Condition (MHz)	Specification			Unit	Remarks
			Min	Typ	Max		
TX to RX	Isolation	882.4~912.6	52	58	-	dB	
		927.4~957.6	48	54	-	dB	
Terminating Impedance	Tx port		50			Ohm	Single-ended
	Rx port		100			Ohm	Differential
	Ant port		50//5.8nH			Ohm	Single-ended
Operating Temperature			-20 to +85			oC	

6. Typical frequency response

Tx to Ant

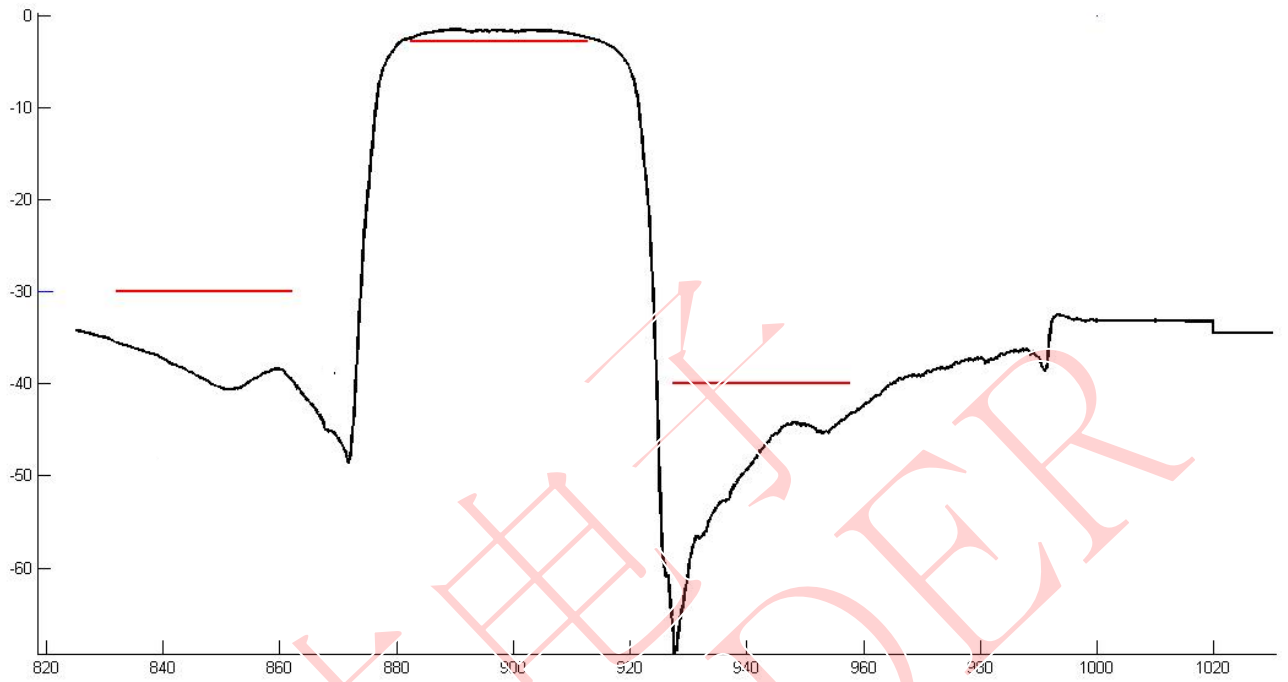

Ant to Rx

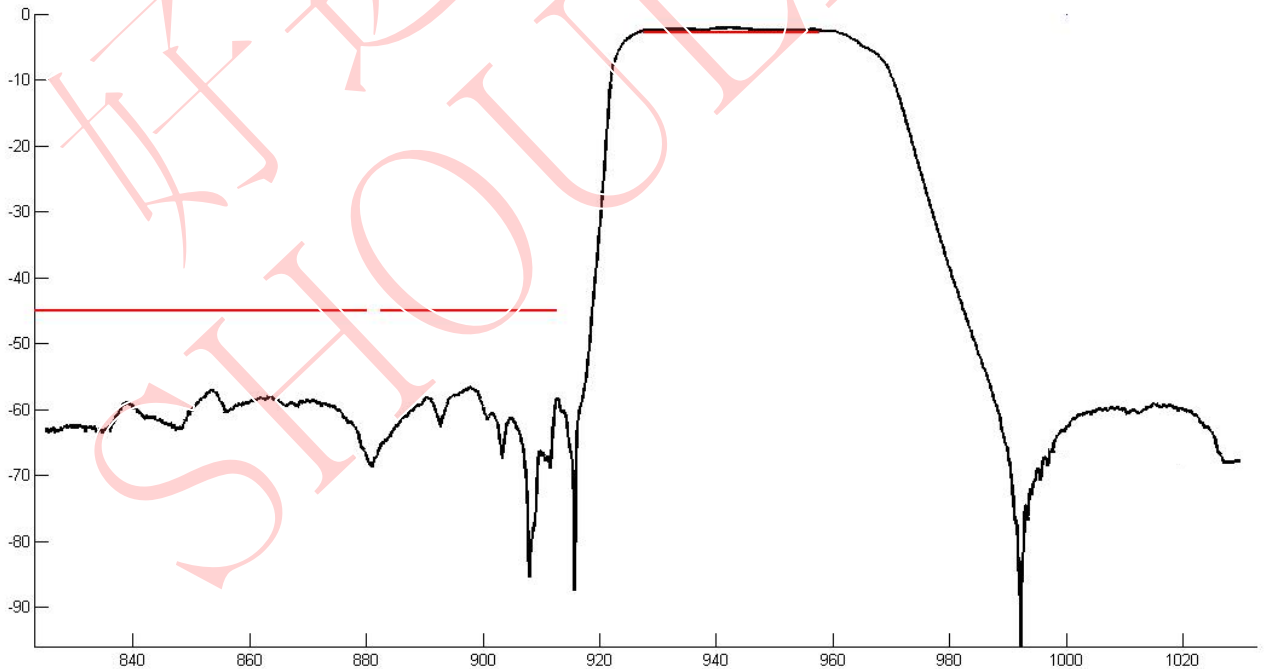

Tx to Rx Isolation

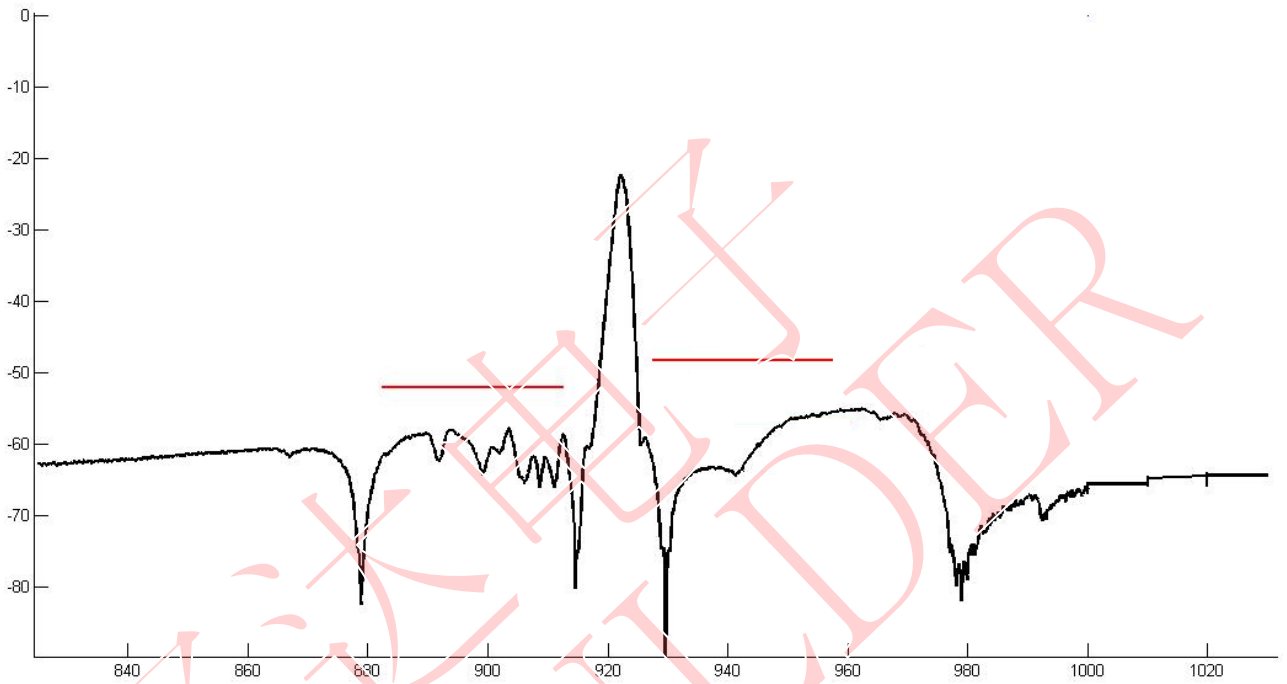

7. Recommended use circuit

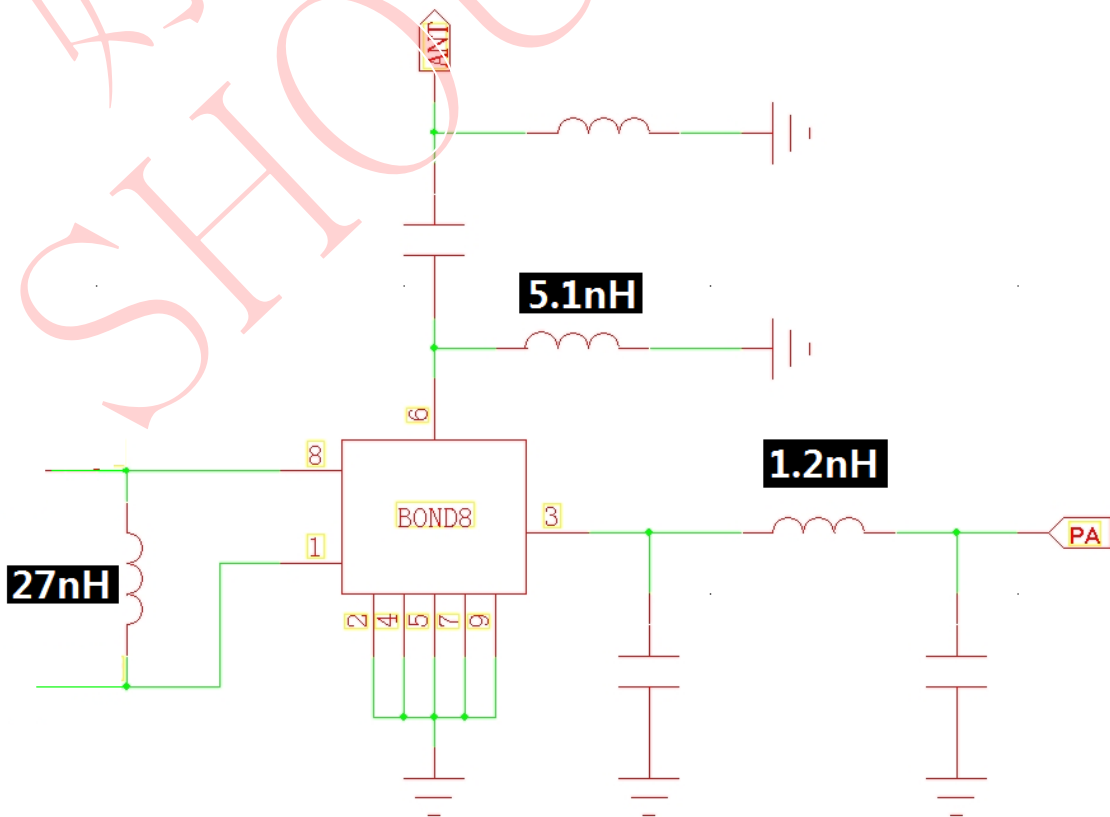

8. ENVIRONMENTAL CHARACTERISTICS

8.1 High temperature exposure

Subject the device to +85°C for 16 hours. Then release the filter into the room conditions for 24 hours prior to the measurement. It shall fulfill the specifications in 5.

8.2 Low temperature exposure

Subject the device to -40°C for 16 hours. Then release the device into the room conditions for 24 hours prior to the measurement. It shall fulfill the specifications in 5.

8.3 Temperature cycling

Subject the device to a low temperature of -40°C for 30 minutes. Following by a high temperature of +85°C for 30 Minutes. Then release the device into the room conditions for 24 hours prior to the measurement. It shall meet the specifications in 5.

8.4 Resistance to solder heat

- 1、immerge the solder bath at 260°C for 10 sec.
- 2、the iron at 370°C for 3 sec

8.5 Solderability

Submerge the device terminals into the solder bath at 245°C ± 5°C for 5s, More than 95% area of the soldering pad must be covered with new solder. It shall meet the specifications in 5.

8.6 Reflow soldering

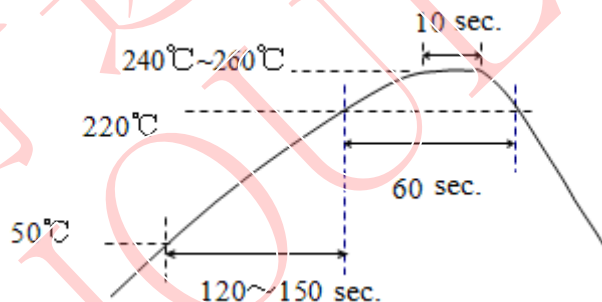

The specimen shall be passed through the reflow furnace with the condition shown in the above profile for 1 time.

The specimen shall be stored at standard atmospheric conditions for 1h, after which the measurement shall be made. Test board shall be 1.6 mm thick. Base material shall be glass fabric base epoxy resin.

8.7 Mechanical shock

Drop the device randomly onto the concrete floor from the height of 1m 3 times. the device shall fulfill the specifications in 5.

8.8 Vibration

Subject the device to the vibration for 1 hour each in x,y and z axes with the amplitude of 1.5 mm at 10 to 55 Hz. The device shall fulfill the specifications in 5.

9. REMARK

9.1 Static voltage

Static voltage between signal load & ground may cause deterioration & destruction of the component. Please avoid static voltage.

9.2 Ultrasonic cleaning

Ultrasonic vibration may cause deterioration & destruction of the component. Please avoid ultrasonic cleaning

9.3 Soldering

Only pad component may be solded. Please avoid soldering another part of component.

10. Packing

10.1 Dimensions

(1) Carrier Tape: Figure 1

(2) Reel: Figure 2

(3) The product shall be packed properly not to be damaged during transportation and storage.

10.2 Reeling Quantity

10000 pcs/reel ϕ 257.5mm

10.3 Taping Structure

(1) The tape shall be wound around the reel in the direction shown below.

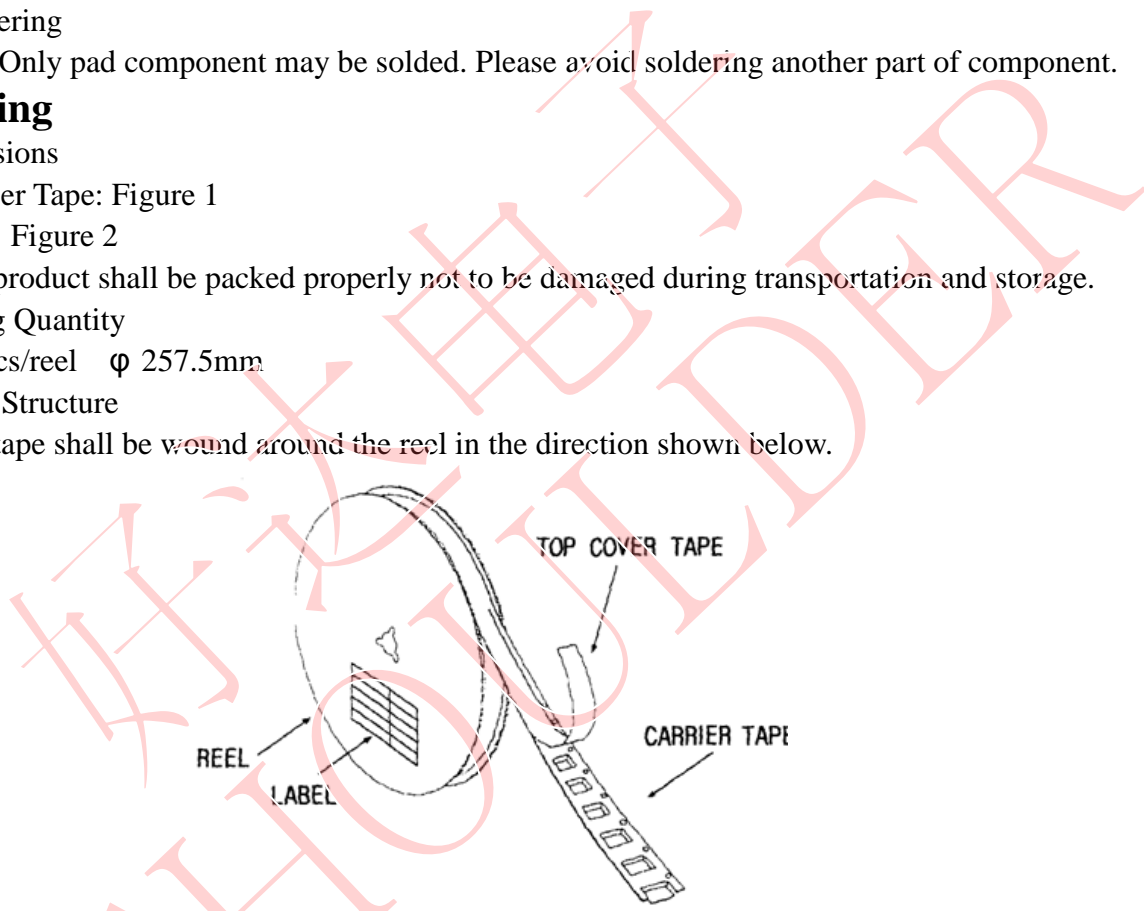

(2) Label

Device Name	
Marking	
User Product Name	
Quantity	
Lot No.	

(3) Leader part and vacant position specifications.

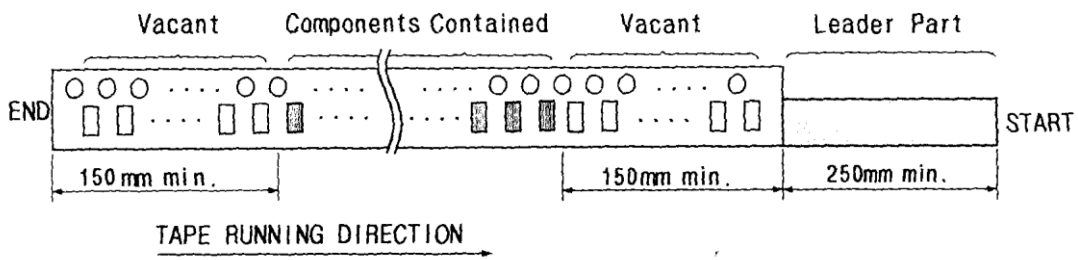

11. TAPE SPECIFICATIONS

11.1 Tensile Strength of Carrier Tape: 4.4N/mm width

11.2 Top Cover Tape Adhesion (See the below figure)

- (1) pull off angle: 0~15°
- (2) speed: 300mm/min.
- (3) force: 20~70g

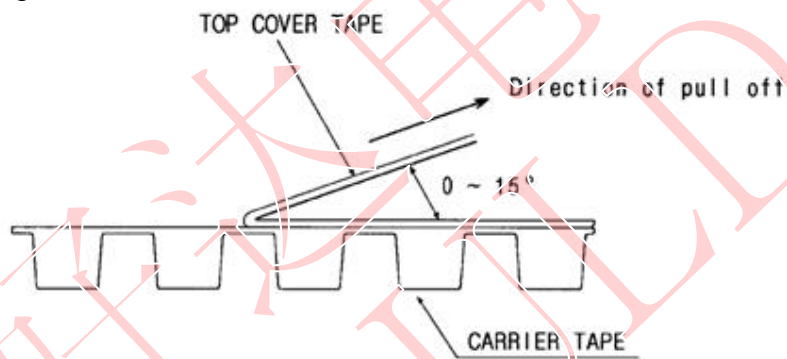

[Figure 1] Carrier Tape Dimensions

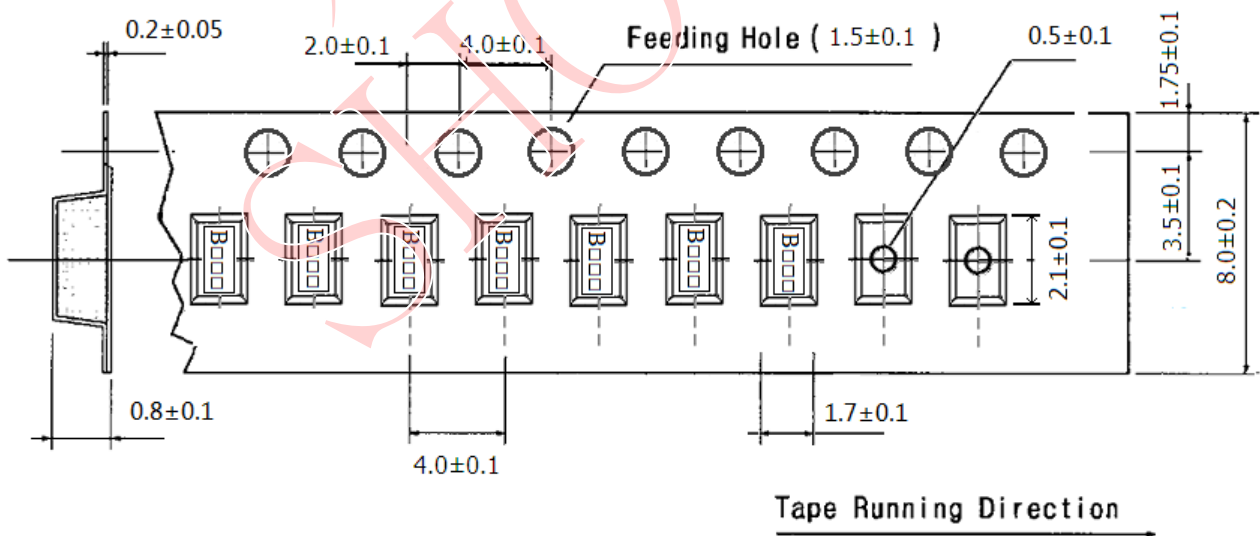

[Figure 2] 10000 pcs/reel ϕ 257.5mm

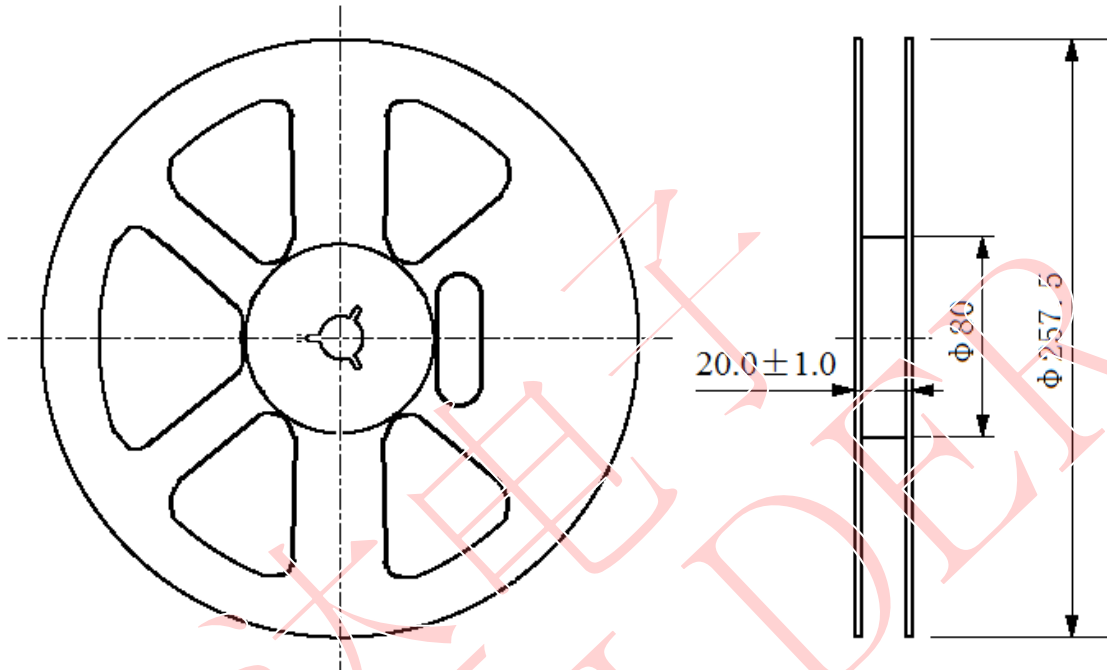

ϕ 257.5 Reel Dimension

(in mm)