

规格书编号

SPEC NO :

产品规格书

SPECIFICATION

CUSTOMER 客户: _____
PRODUCT 产品: _____ SAW FILTER _____
MODEL NO 型号: _____ HDF4553 _____
PREPARED 编制: _____ CHECKED 审核: _____
APPROVED 批准: _____ D A T E 日期: _____ 2007-7-14 _____

客户确认 CUSTOMER RECEIVED:		
审核 CHECKED	批准 APPROVED	日期 DATE

无锡市好达电子有限公司
Shoulder Electronics Limited

更改历史记录 History Record

更改日期 Date	规格书编号 Spec. No.	产品型号 Part No.	客户产品型号 Customer No.	更改内容描述 Modify Content	备注 Remark

1.Features

- _ RF bandpass filter for CDMA450 A-Band Tx. Part
- _ Usable bandwidth 5MHz (452.5 MHz ~ 457.5 MHz)
- _ High attenuation
- _ No matching single-ended operation
- _ Ceramic Surface Mounted Device Package (3.0 mm × 3.0mm)
- _ RoHS Compliant

2. ELECTRICAL SPECIFICATION

Parameter	Rating	Unit
Operating Temperature Range	-30~85	°C
Storage Temperature Range	-40~85	°C
Power Handling Capability	30	dBm

Electronic Characteristics

2-1. Typical frequency response

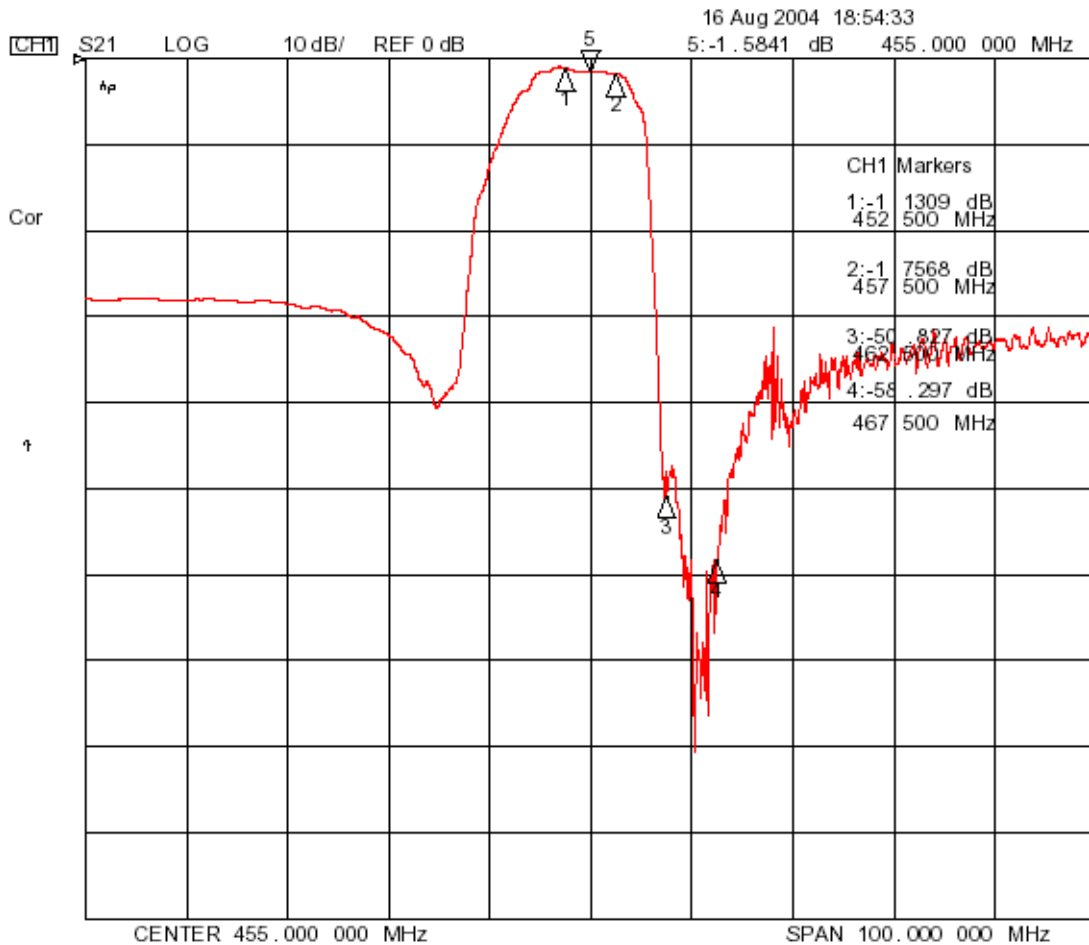

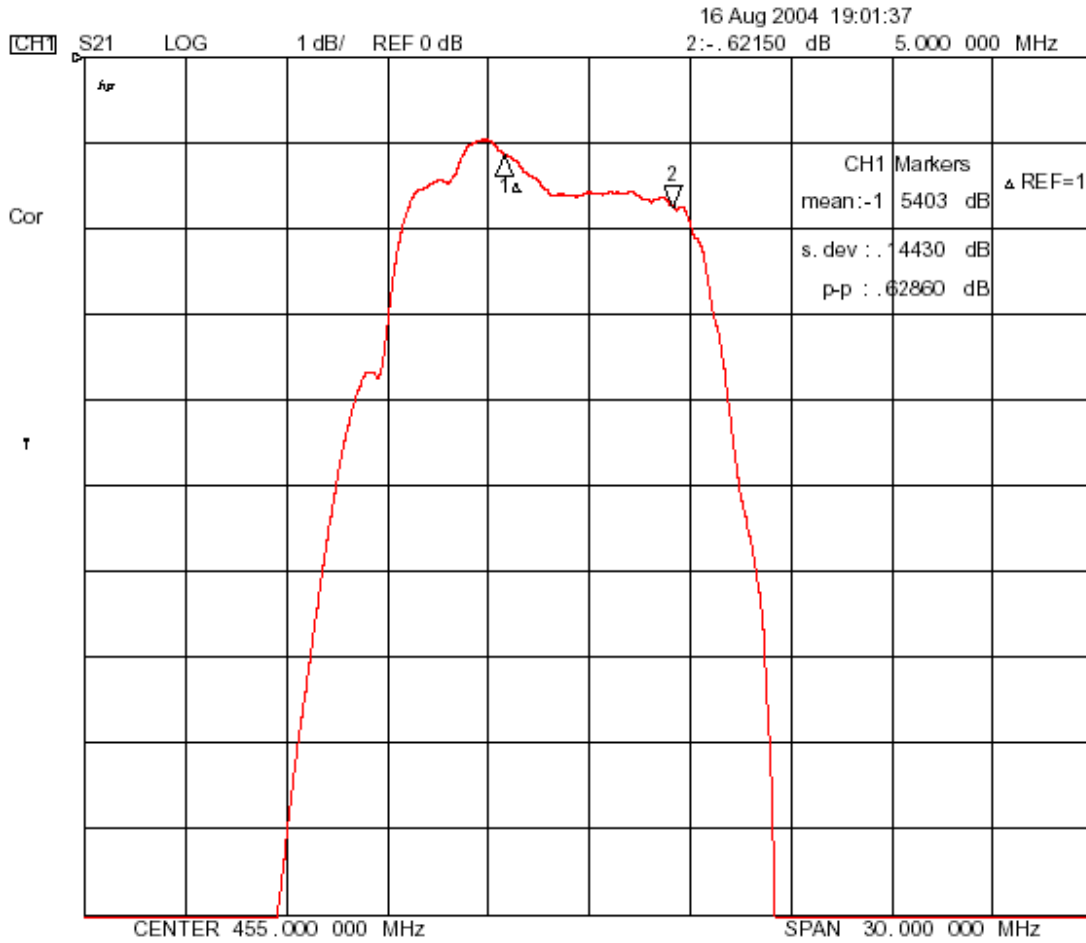

2-2 Input / Output VSWR Charts

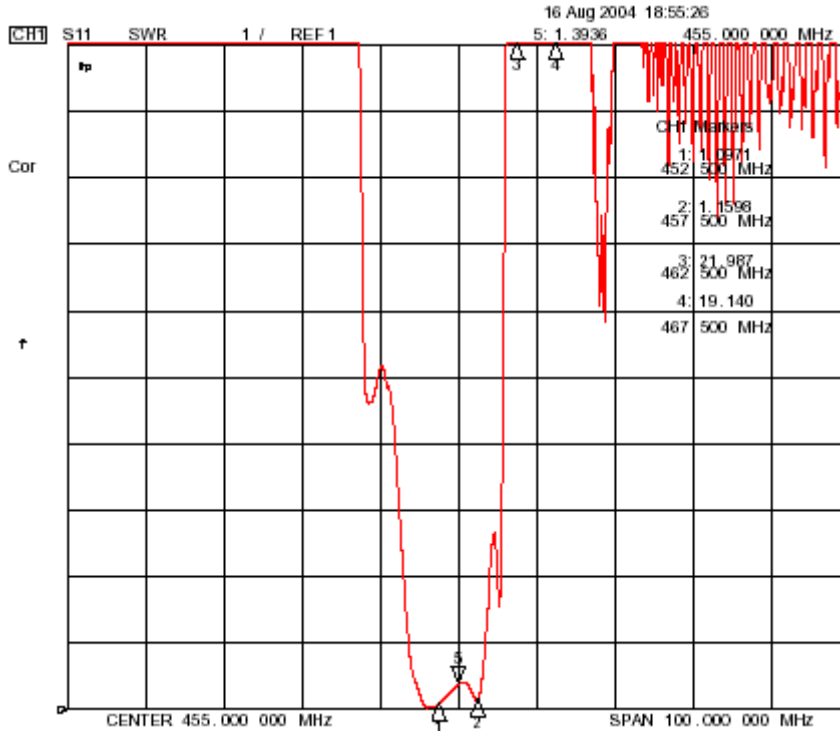

2-3. Electrical characteristics

		Minimum	Typical	Maximum
Center Frequency (F0)	MHz	-	455.0	-
Insertion Loss (F0 +/- 2.5 MHz)	dB	-	2.0	2.8
Amplitude Ripple (F0 +/- 2.5 MHz)	dB	-	0.8	1.5
VSWR (F0 +/- 2.5 MHz)		-	1.4	2.0
Relative Attenuation				-
0.3 MHz ~ 350.0 MHz	dB	25	30	
350.0 MHz ~ 441.5 MHz		25	30	
462.5 MHz ~ 467.5 MHz		38	50	
467.5 MHz ~ 1200 MHz		25	30	
1200 MHz ~ 2000 MHz		20	-	
Input/Output Impedance	Ω	-	50	-

3. TEST CIRCUIT

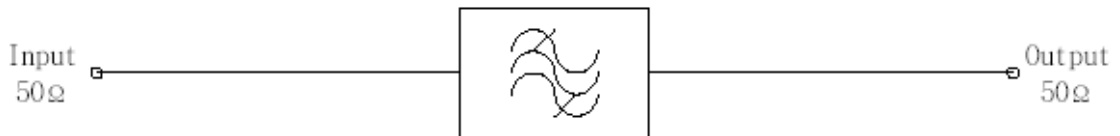

4-1. DIMENSION

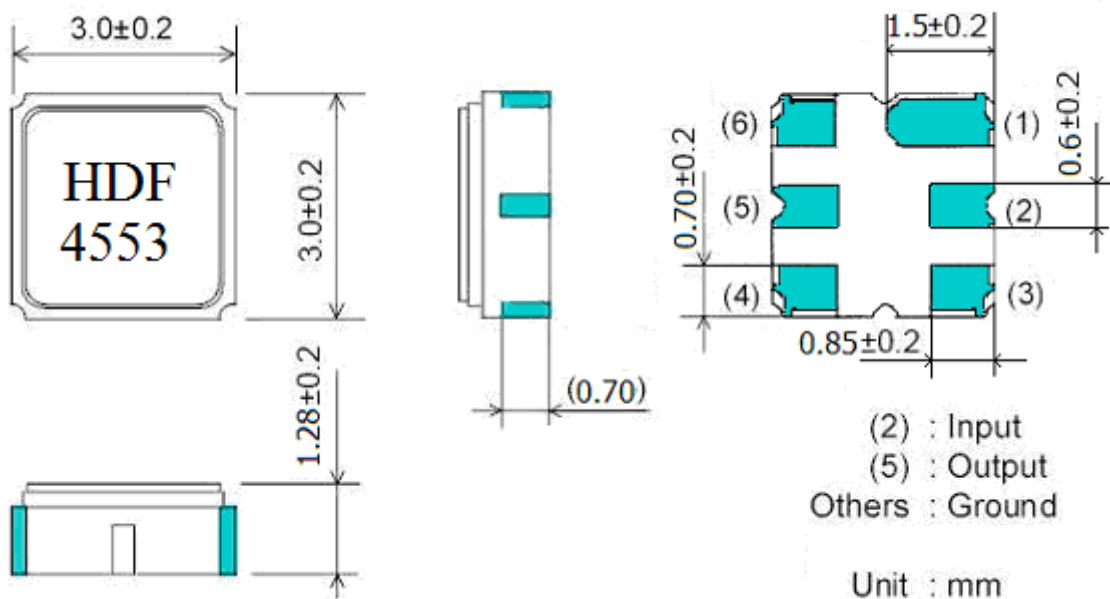

5. Environmental Performance Characteristics

Item	Condition	Specifications																						
High temperature	The specimen shall be store at a temperature of $85\pm 2^{\circ}\text{C}$ for $96\pm 4\text{h}$. Then it shall be subjected to standard atmospheric conditions for 1h, after which measurement shall be made within 1h.	Mechanical characteristics and specifications in electrical characteristics shall be satisfied. There shall be no excessive change in appearance.																						
Low temperature	The specimen shall be store at a temperature of $-30\pm 3^{\circ}\text{C}$ for $96\pm 4\text{h}$. Then it shall be subjected to standard atmospheric conditions for 1h, after which measurement shall be made within 1h.																							
Humidity	The specimen shall be store at a temperature of $40\pm 2^{\circ}\text{C}$ with relative humidity of 90% to 96% for $96\pm 4\text{h}$. Then it shall be subjected to standard atmospheric conditions for 1h, after which measurement shall be made within 1h.																							
Thermal shock	The specimen shall be subjected to 8 continuous cycles each as shown below. Then it shall be subjected to standard atmospheric conditions for 1h, after which measurement shall be made within 1h.																							
			<table border="1"> <thead> <tr> <th></th> <th>Temperature</th> <th>Duration</th> </tr> </thead> <tbody> <tr> <td>1</td> <td>$+25^{\circ}\text{C} \Rightarrow -40^{\circ}\text{C}$</td> <td>0.5h</td> </tr> <tr> <td>2</td> <td>-40°C</td> <td>4h</td> </tr> <tr> <td>3</td> <td>$-40^{\circ}\text{C} \Rightarrow +85^{\circ}\text{C}$</td> <td>2h</td> </tr> <tr> <td>4</td> <td>$+85^{\circ}\text{C}$</td> <td>4h</td> </tr> <tr> <td>5</td> <td>$+85^{\circ}\text{C} \Rightarrow +25^{\circ}\text{C}$</td> <td>0.5h</td> </tr> <tr> <td>6</td> <td>$+25^{\circ}\text{C}$</td> <td>1h</td> </tr> </tbody> </table>		Temperature	Duration	1	$+25^{\circ}\text{C} \Rightarrow -40^{\circ}\text{C}$	0.5h	2	-40°C	4h	3	$-40^{\circ}\text{C} \Rightarrow +85^{\circ}\text{C}$	2h	4	$+85^{\circ}\text{C}$	4h	5	$+85^{\circ}\text{C} \Rightarrow +25^{\circ}\text{C}$	0.5h	6	$+25^{\circ}\text{C}$	1h
			Temperature	Duration																				
	1	$+25^{\circ}\text{C} \Rightarrow -40^{\circ}\text{C}$	0.5h																					
	2	-40°C	4h																					
	3	$-40^{\circ}\text{C} \Rightarrow +85^{\circ}\text{C}$	2h																					
4	$+85^{\circ}\text{C}$	4h																						
5	$+85^{\circ}\text{C} \Rightarrow +25^{\circ}\text{C}$	0.5h																						
6	$+25^{\circ}\text{C}$	1h																						
Resistance to Soldering heat	Reflow soldering method																							
	Peak: $255 \pm 5^{\circ}\text{C}$, $220 \pm 5^{\circ}\text{C}$, 40s At electrode temperature of the specimen.																							

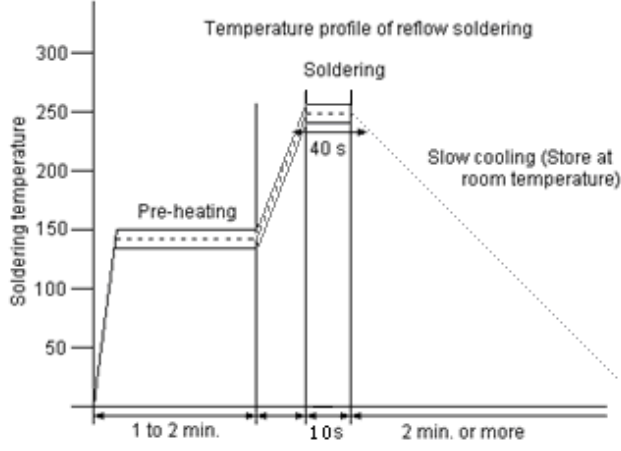
	 <p>The specimen shall be passed through the reflow furnace with the condition shown in the above profile for 1 time. The specimen shall be stored at standard atmospheric conditions for 1h, after which the measurement shall be made. Test board shall be 1.6 mm thick. Base material shall be glass fabric base epoxy resin.</p>	
Solder ability	Immerse the pins melt solder at 260°C+5/-0°C for 5 sec.	More then 95% of total area of the pins should be covered with solder

6. Mechanical Test

Items	Conditions	Specifications
Vibration	600-3300rpm amplitude 1.5mm 3 directions 2 H each	There shall be no damage.
Drop	On maple plate from 1m high 3 times	
Lead pull	Pull with 1kg force for 30 seconds	
Lead bend	90° bending with 500g weigh 2 times	

7. REMARK

7.1 Static voltage

Static voltage between signal load & ground may cause deterioration & destruction of the component. Please avoid static voltage.

7.2 Ultrasonic cleaning

Ultrasonic vibration may cause deterioration & destruction of the component. Please avoid ultrasonic cleaning

7.3 Soldering

Only leads of component may be soldered. Please avoid soldering another part of component.

8. Packing

8.1 Dimensions

- (1) Carrier Tape: Figure 1
- (2) Reel: Figure 2
- (3) The product shall be packed properly not to be damaged during transportation and storage.

8.2 Reeling Quantity

- 1000 pcs/reel 7"
3000 pcs/reel 13"

8.3 Taping Structure

- (1) The tape shall be wound around the reel in the direction shown below.

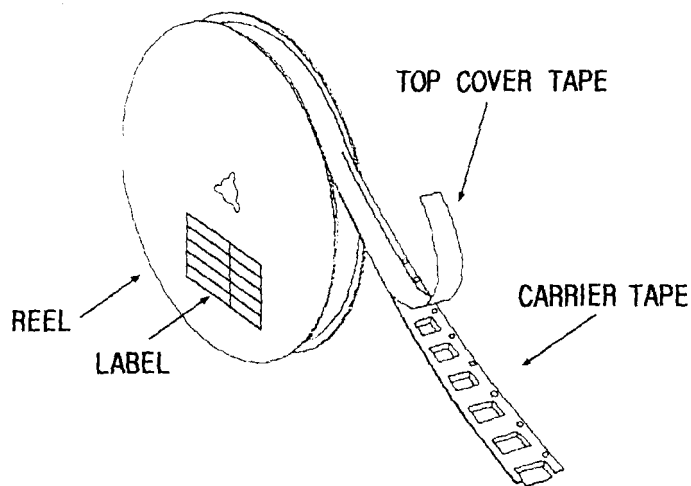

- (2) Label

Device Name	
User Product Name	
Quantity	
Lot No.	

- (3) Leader part and vacant position specifications.

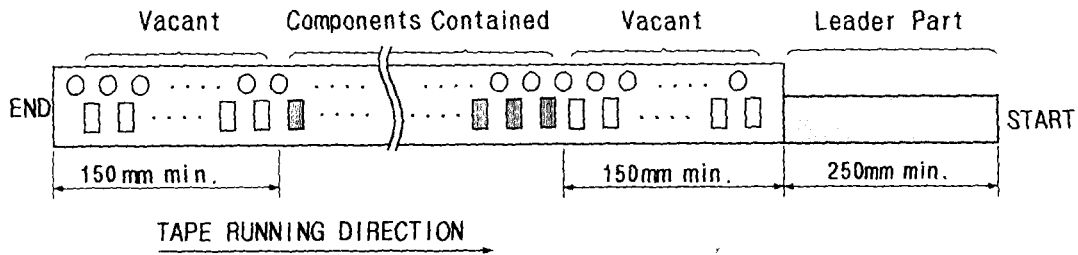

9. TAPE SPECIFICATIONS

9.1 Tensile Strength of Carrier Tape: 4.4N/mm width

9.2 Top Cover Tape Adhesion (See the below figure)

- (1) pull off angle: 0~15°
- (2) speed: 300mm/min.
- (3) force: 20~70g

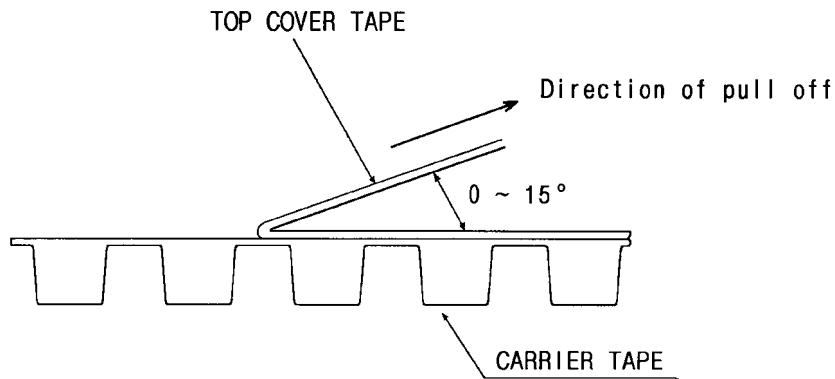

[Figure 1] Carrier Tape Dimensions

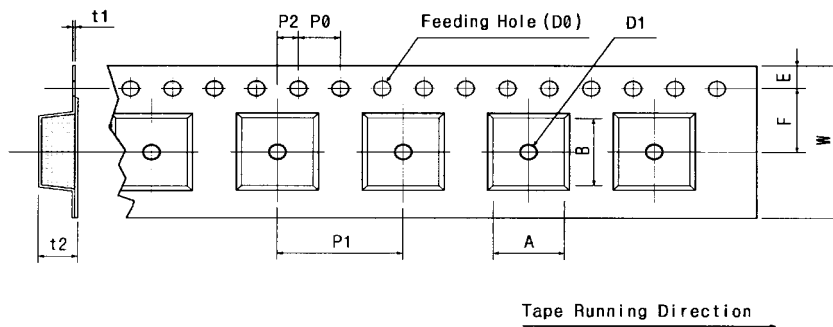

[Unit:mm]

W	F	E	P0	P1	P2	D0	D1	t1	t2	A	B
12.00	5.50	1.75	4.00	4.00	2.00	Ø1.50	Ø1.5	0.31	1.30	3.4	3.4
±0.30	±0.10	±0.10	±0.10	±0.10	±0.10		±0.25	±0.05	±0.10	MAX.	MAX

[Figure 2]

[Unit:mm]

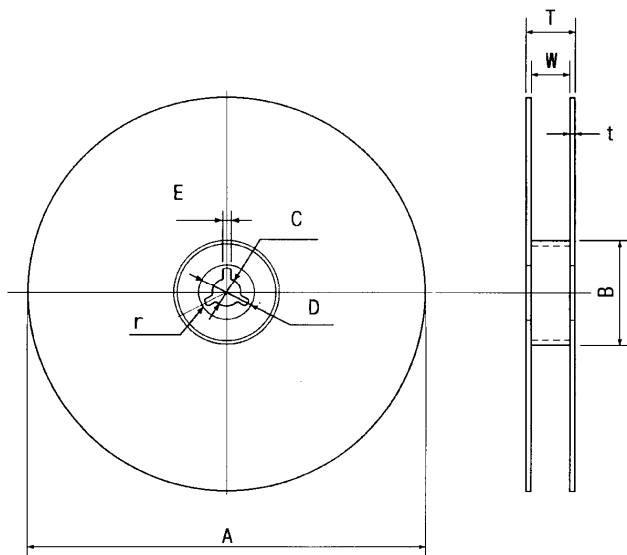

A	B	C	D	E	W	t	r
Ø330	Ø100	Ø13	Ø21	2	13	3	1.0
±1.0	±0.5	±0.5	±0.8	±0.5	±0.3	max.	max.